

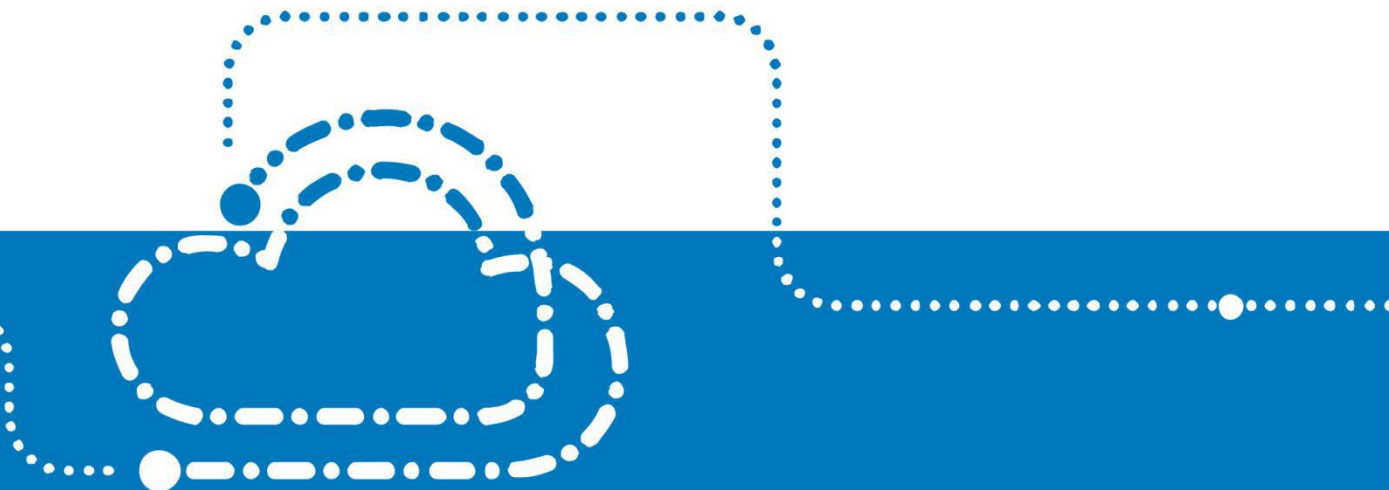

Operator Logo

ZXHN F6600R Product Description



ZXHN F6600R Product Description

Version	Date	Author	Reviewer	Notes
V1.0	2021/12/17	ZTE		Process Version draft, not open to the third party

© 2024 ZTE Corporation. All rights reserved.

ZTE CONFIDENTIAL: This document contains proprietary information of ZTE and is not to be disclosed or used without the prior written permission of ZTE.

Due to update and improvement of ZTE products and technologies, information in this document is subjected to change without notice.

TABLE OF CONTENTS

TABLES.....	4
1 Overview.....	4
1.1 Product Positioning.....	4
1.2 Network Applications.....	5
2 Product Highlights.....	7
2.1 High Reliability.....	7
2.2 Enriched User-Side Interfaces.....	7
2.3 Gigabit Wi-Fi Access and USB.....	8
2.4 Eco-Friendly Design.....	8
2.5 Convenient Installation and Management.....	8
3 Hardware Features.....	9
3.1 Physical Interfaces and buttons.....	9
3.2 LED Indicators.....	11
4 System Features.....	13
4.1 GPON Features.....	13
4.1.1 Bandwidth Allocation.....	13
4.1.2 GEM Adaptation.....	14
4.1.3 T-CONT.....	14
4.1.4 Operation and Maintenance.....	14
4.1.5 Optical Link Analysis and Diagnosis.....	14
4.2 Ethernet Features.....	15
4.2.1 MAC Address Features.....	15
4.2.2 VLAN Features.....	15
4.3 Wi-Fi Features.....	16
4.4 VoIP Features.....	17
4.4.1 SIP Protocol.....	17
4.4.2 Voice Codec.....	18
4.4.3 Supplementary Services.....	18
4.4.4 Advanced Features.....	18
4.5 USB Features.....	19
4.6 CATV Features.....	19
4.7 QoS Features.....	20
4.8 Multicast Features.....	20
4.9 L3 Features.....	20
4.10 IPv6 Features.....	21

4.11 Management Features.....	22
4.12 Security Features.....	22
4.12.1 Data Security of the GPON Interface.....	22
4.12.2 Traffic Suppression.....	23
4.13 Alarm Features.....	23
4.14 Performance Statistic Features.....	23
4.14.1 Ethernet Port Performance Parameters.....	23
5 Technical Indices and Parameters.....	25
5.1 Physical Structure, Environmental and Electrical Indices.....	25
5.2 GPON Interface Indices and Parameters.....	25
5.3 Key Technical Indices.....	26
6 Standards Compliance.....	27
7 Glossary.....	29

FIGURES

Figure 1-1	ZXHN F6600R Housing Design.....	5
Figure 1-2	Network Topology of the ZXHN F6600R.....	6
Figure 3-1	Rear Panel of the ZXHN F6600R.....	9
Figure 3-2	LED Indicators of the ZXHN F6600R.....	11

TABLES

Table 3-1	Specifications for the Interfaces and buttons on the ZXHN F6600R	9
Table 3-3	Specification for the LED Indicators of the ZXHN F6600R.....	11
Table 5-1	Specifications and Environmental Indices of the ZXHN F6600R.....	25
Table 5-2	GPON Interface Indices of the ZXHN F6600R.....	25
Table 5-3	Key Technical Indices of the ZXHN F6600R.....	26
Table 6-1	Standards Compliance.....	27
Table 7-1	Glossary.....	29

1 Overview

1.1 Product Positioning

The ZXHN F6600R is an ITU-T G.984 and ITU-T G.988 compliant optical network terminal (ONT) that is designed for high-end home users. It is well suited to fiber to the home (FTTH) scenarios and supports desktop mounting. At the network side, it supports

2.488 Gbps downlink and 1.244 Gbps uplink. At the user side, it provides four GE ports, one POTS port, one USB 2.0 port, one RF port, and 2x2 802.11b/g/n/ax@2.4GHz & 2x2 802.11a/n/ac/ax@5GHz concurrent.

Figure 1-1 ZXHN F6600R Housing Design



1.2 Network Applications

The ZXHN F6600R is an ONT designed for FTTH application scenarios. By using the ZXHN F6600R, the home users can access data, video and voice services, and enjoy high-speed Internet access. Figure 1-2 illustrates the application scenarios of the ZXHN F6600R:

Figure 1-2 Network Topology of the ZXHN F6600R

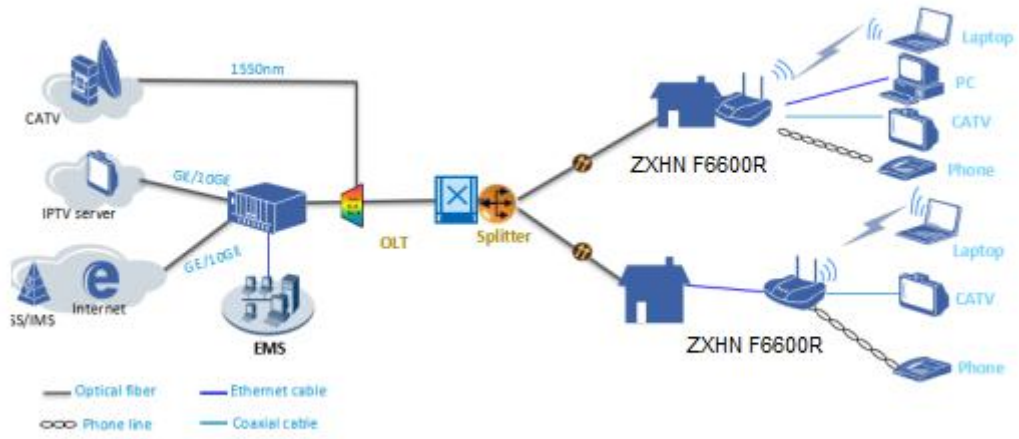

2 Product Highlights

2.1 High Reliability

- The full-service access capability featuring high bandwidth, high performance, high reliability, and easy operation, administration and maintenance (OMCI/TR-069) meets the ever changing customer requirements, protects legacy investments, and enhances the value of operators' networks.
- The highly reliable heat dissipation design guarantees stable operation.
- The dual image ensures uninterrupted services during software downloads or upgrades, thereby enhancing software reliability.
- The highly reliable lightning protection design provides lightning and surge protection of 4 kV for the adapter, 1.5 kV for the POTS port, and 1.5 kV for the Ethernet ports.

2.2 Enriched User-Side Interfaces

- Provides four GE ports for HSI or HD VoD services.
- Provides one FXS port for traditional telephone services.
- Provides one RF port for CATV services.
- Provides one USB 2.0 port for file storage and sharing, print sharing and user configuration file fast recovery.
- Supports dual band concurrent Wi-Fi up to 574Mbps (802.11ax 2x2 @ 2.4GHz) and 2402Mbps (802.11ax 2x2 @5GHz).
- Users can connect PCs, IPTV STBs, tablets, smartphones, phones, faxes, and other terminals to the ZXHN F6600R to enjoy all kinds of Internet services.

2.3 Gigabit Wi-Fi Access and USB

- Users can build a convenient and secure wireless LAN, and access the Internet flexibly and reliably.
- Complies with the IEEE 802.11b/g/n/ax@2.4GHz (MIMO 2*2) standard.
- Complies with the IEEE 802.11a/n/ac/ax@5GHz (MIMO 2*2) standard.
- Supports WPA2-PSK and WPA3-PSK authentication to ensure safe and reliable home Wi-Fi access.
- Provides the file storage and sharing function so that users can enjoy photos, music and videos through connecting storage devices to the USB port.
- Supports USB host ports that comply with USB 2.0 specifications, and supports FAT, FAT32, NTFS partition format and mainstream storage devices on the market.

2.4 Eco-Friendly Design

- Automatically switches to energy-saving mode according to traffic status and busy/idle status of the port.

2.5 Convenient Installation and Management

- Remote batch upgrade, fault diagnosis, port loopback, and link detection via the OMCI/TR-069.
- Software upgrade and management via the EMS/ACS/OLT.
- Local Web management.
- Offline & batch configuration.

3 Hardware Features

3.1 Physical Interfaces and buttons

The ZXHN F6600R includes one GPON optical port, four 10/100/1000M Ethernet ports, one POTS port, one USB port, one RF port, and 2x2 802.11b/g/n/ax@2.4GHz & 2x2 802.11a/n/ac/ax@5GHz concurrent.

The ZXHN F6600R provides one Wi-Fi button, one WPS button, one On/Off button and one Reset button.

Figure 3-1 Rear Panel of the ZXHN F6600R



Table 3-1 Specifications for the Interfaces and buttons on the ZXHN F6600R

Interface	Description
PON	SC/APC GPON optical interface.
LAN1-LAN4	Supports four 10/100/1000Base-T Ethernet ports with RJ-45 connector. Supports half/full duplex and flow control, auto negotiation or

Interface	Description
	manual configuration. Supports MDI/MDIX auto-sensing.
Phone	Supports one POTS port with RJ-11 connector.
CATV	Supports one RF port.
USB	Supports one USB host interface. Complies with USB 2.0 specifications.
Reset	When the ZXHN F6600R is powered on, press and hold the Reset button for one second to restart the ZXHN F6600R. The user's settings information will not be lost. When the ZXHN F6600R is powered on, press and hold the Reset button for more than five seconds to restore the ZXHN F6600R to the factory settings.
Power	12 V Power Input Interface. +12 V DC (via external AC/DC adapter: 90 - 264 V, 50/60 Hz AC input, 12 V DC output).
On/Off	Power switch.
WPS	After pushing the WPS button for longer than 0.4s, the WPS function will be enabled.
Wi-Fi	After pushing the Wi-Fi button for longer than 0.4s, the WLAN function will be enabled or disabled.

The Wi-Fi button, WPS button are on a side of the ZXHN F6600R device.

3.2 LED Indicators

Figure 3-2 LED Indicators of the ZXHN F6600R



Table 3-3 Specification for the LED Indicators of the ZXHN F6600R

LED	Color	Status Description
Power	Off	The device is powered off.
	Solid green	The device is powered on.
PON	Off	The device is powered off or the device has not started the registration process.
	Solid green	The device registration is successful.
	Slow Flashing green	The device is registering.
	Fast Flashing green	The device is upgrading.
LOS	Off	The device is powered off or the device received optical power is normal.
	Solid red	The optical transmitter of the PON interface is powered off.
	Flashing red	The received optical power is less than the optical receiver sensitivity.
Internet	Off	The device is powered off or there is no WAN connection with Internet properties configured, or the session is disconnected on user request or remote peer request (PPP disconnected, DHCP address

LED	Color	Status Description
		released or no static IP address available on the Internet WAN connection).
	Solid green	There is IP connected (the ONT has a Internet WAN IP address from IPCP, DHCP or statically configured).
	Flashing green	IP traffic is passing through the Internet WAN connection (either direction).
LAN1-LAN 4	Off	The device is powered off or the network link is not established.
	Solid green	The Ethernet port is connected but no data is transmitted via the Ethernet port.
	Flashing green	Data is being transmitted or received via the Ethernet port.
Phone	Off	The device is powered off or the device is unable to register on the soft switch/IMS.
	Solid green	The device has registered on the soft switch/IMS but no traffic is being transmitted.
	Flashing green	The voice service traffic is being transmitted or received.
2.4G, 5G	Off	The device is powered off or the wireless interface is disabled.
	Solid green	The wireless interface is enabled but no data is being transmitted or received.
	Flashing green	Data is being transmitted or received on the wireless interface.
WPS	Off	The device is powered off or the WPS function is disabled.
	Solid green	Some device has connected the device Wi-Fi using WPS.
	Flashing yellow	Some devices are trying to connect to the device.
	Flashing red	Session is detected overlapping or negotiation fails.
CATV	Off	The device is powered off or CATV interface is disabled.
	Solid green	The CATV interface is in use, and the received optical power is between -10 dB and 2 dB.

4 System Features

4.1 GPON Features

- ITU-T G.984 and ITU-T G.988 compatible
- Flexible mapping between GEM port and T-CONT
- Priority queuing and scheduling for upstream traffic
- AES-128 encryption
- FEC
- Five types of T-CONT
- Upstream traffic classification based on VLAN ID and 802.1p
- Multicast GEM port
- SN, password, and SN+password authentication
- Auto-restart and recovery after power failure

4.1.1 Bandwidth Allocation

- Static bandwidth allocation
 - ITU-T G.983.1 compliant static bandwidth allocation
- Dynamic bandwidth allocation (DBA)
 - Adopts fair DBA policy for the same CoS services during traffic congestion
 - Dynamic bandwidth status report mode complies with ITU-T G.984.3

4.1.2 GEM Adaptation

- GEM mode
- GEM frame mapping to GTC payload
- Ethernet data frame mapping to GEM frame; Ethernet frame mapping into GEM ports based on VLAN, CoS, or VLAN+CoS

4.1.3 T-CONT

- Five types of T-CONT
- T-CONT as the basic unit of the upstream service
- T-CONT allocation based on the user and CoS; mapping to T-CONT queue based on the CoS value or GEM port
- WRR, SP, or WRR+SP T-CONT queue scheduling mode

4.1.4 Operation and Maintenance

- Physical layer operations and maintenance (PLOAM) defined in ITU-T G.984.3
- OMCI and OMCI extension defined in ITU-T G.984.4 and ITU-T G.988

4.1.5 Optical Link Analysis and Diagnosis

- The optical module diagnostic interface analyses the parameters including operating temperature of the optical module, supply voltage, bias current, transmission power, and receiving power.
- Detection and auto shutdown of rogue ONTs.

4.2 Ethernet Features

4.2.1 MAC Address Features

- MAC address learning
- MAC address aging
- MAC address learning enable/disable
- MAC address learning limit
- MAC address binding to a user port. Only controls the input side of the port.
- Anti-MAC transferring (spoofing)
 - Forbids the MAC addresses learned from a user port to be transferred to other user port before aging.
 - Forbids the MAC addresses learned from an uplink port to be transferred to the user port.
- MAC filtering
 - Both the source and destination MAC addresses support the blacklist and the white list function.

4.2.2 VLAN Features

- IEEE 802.1q VLAN with the VLAN ID from 1 to 4094
- VLAN tagging/untagging on the user port
- VLAN overwrite function on the user port
- 1:1 mapping between the user port (physical port or logical port) and VLAN
- VLAN-based data forwarding
- VLAN-based packet filtering

- VLAN untagged mode, tagged mode and double tagged mode
- VLAN tag
 - Adds S-Tag to the untagged or priority tagged frames from the user port as per the needs.
 - Adds C-Tag and S-Tag to the untagged or priority tagged frames from the user port as needed.

4.3 Wi-Fi Features

The Wi-Fi function provides an easy, convenient, flexible, and cost-efficient method for users to access the Internet via a wireless LAN network.

- Supports 2.4GHz (2* 2 MIMO), IEEE802.11b/g/n/ax compliant
- Supports 5GHz (2* 2 MIMO), IEEE802.11a/n/ac/ax compliant
- Auto and manual channel selection
- Auto and manual rate control
- Transmission power control
- Four SSIDs per frequency band
- Maximum 32 users per frequency band
- SSID broadcast enabling/disabling
- Access control based on MAC address
- WPS
- WMM
- Beamforming
- MU-MIMO

4.4 VoIP Features

4.4.1 SIP Protocol

- RFC 2617: HTTP Authentication: Basic and Digest Access Authentication.
- RFC 2833: RTP Payload for DTMF Digits, Telephony Tones and Telephony Signals
- RFC 3261: SIP: Session Initiation Protocol
- RFC 3262: Reliability of Provisional Responses in the Session Initiation Protocol (SIP)
- RFC 3263: Session Initiation Protocol (SIP): Locating SIP Servers
- RFC 3264: Offer/Answer Model with Session Description Protocol (SDP)
- RFC 3265: SIP Specific Event Notification
- RFC 3311: The Session Initiation Protocol UPDATE Method
- RFC 3323: A Privacy Mechanism for the Session Initiation Protocol (SIP), For further information see the CLIP/CLIR/CNIP/CNIR document.
- RFC 3325: Private Extensions to the Session Initiation Protocol (SIP) for Asserted Identity within Trusted Networks
- RFC 3515: The Session Initiation Protocol (SIP) - Refer Method
- RFC 3581: An Extension to the Session Initiation Protocol (SIP) for Symmetric Response Routing.
- RFC 3842: A Message Summary and Message Waiting Indication Event Package for the Session Initiation Protocol (SIP)
- SDP: draft-ietf-mmusic-sdp-new-24.txt
- RFC 3891: The Session Initiation Protocol (SIP) "Replaces" Header

- RFC 3960: Early Media and Ringing Tone Generation in the Session Initiation Protocol(SIP)
- RFC 3966: The Tel URI for Telephone Numbers
- RFC 4028: Session Timers in the Session Initiation Protocol (SIP)

4.4.2 Voice Codec

- G.711a/u law
- G.729
- G.722

4.4.3 Supplementary Services

- Call Forwarding Unconditional (CFU)
- Call Forwarding No Answer/On no Reply (CFNA)
- Call Forwarding on Busy (CFB)
- Calling Line Identity Presentation (CLIP)
- Calling Line Identity Restriction (CLIR)
- Internal call between FXS

4.4.4 Advanced Features

- Digit Map and Call Routing Management
- Voice Activity Detection (VAD)/ Silence Suppression
- Comfort Noise Generation (CNG)
- DTMF tone detection and generation
- Fax / Modem detection and pass-through

- Support in-band DTMF tone sending/receiving and out-band DTMF signaling with RTP
- Packet Loss Concealment
- Echo Cancellation
- Fixed and adaptive jitter buffer
- Fax over IP
 - T.30 Fax Pass-through
 - T.38 Fax Relay

4.5 USB Features

- One USB 2.0 host port
- Supports file storage and sharing
- Supports print sharing
- Supports user configuration file fast recovery

4.6 CATV Features

- Standard F-Type connector
- Analog RF video over dedicated 1550nm wavelength
- RF output level of +17 dBmV±2dB
- RF Passband: 46 MHz-1 GHz
- Switched on/off by remote control
- Receiving sensitivity: - 10 to 2 dBm AGC dynamic range

4.7 QoS Features

- Traffic rate limiting based on the user port, traffic, and GEM port
- Upstream traffic classification based on VLAN ID, VLAN priority level (IEEE802.1D), and Ethernet type (such as IP, PPPoE and ARP/RARP)
- Ethernet priority level tagging of the upstream services based on the DSCP value
- Ingress rate limiting
- Egress shaping

4.8 Multicast Features

- IGMP v1/v2v3 and MLD Snooping
- IGMP PROXY
- 256 multicast groups per LAN port
- Fast leave time-the interval, from when a user sends an IGMP leaving message to when the ONU stops the multicast data packet, is less than 20ms.
- Supports MVLAN

4.9 L3 Features

- Data forwarding and routing
 - Bridging, routing, or hybrid mode (bridging and routing)
 - Static routing
- Address management
 - DHCP server/client, Option 60

- DHCP client, options 6, 15, 42, 50, 60, and 120
- PPPoE client
- DNS client/relay
- SNTP client
- NAT
- ALG function: implements H.323, SIP, FTP, TFTP, PPTP, L2TP, IPSec, and RTSP private network traversal function; provides separate switches for each ALG function.

4.10 IPv6 Features

- Transparent transmission of IPv6 protocol packets
- IPv4/IPv6 dual stack
- MLD v1 and MLD snooping
- IPv6 address management
 - SLAAC allocation mode on LAN side
 - DHCPv6 on LAN side
 - SLAAC on WAN side
 - DHCPv6 on WAN side
 - DHCPv6-PD on WAN side
 - PPPoE+DHCPv6 on WAN side
 - PPPoE+SLAAC on WAN side

4.11 Management Features

- OMCI management
- Web management
- TR-069 management
- Management via the OLT on the EMS
- Built-in capability for remote management with standards compliance, including the full range of FCAPS functions like supervision, analysis, and maintenance
- UNI loopback detection
- Remote software download, activation, and reboot via the OMCI
- Dual image, version download, update detection, and auto rollback

4.12 Security Features

- Traffic filtering based on UNI, VLAN ID, 802.1p, UNI + 802.1p, and VLAN + 802.1p
- Multicast , unicast and broadcast flow attack protection
- MAC address limiting based on each UNI or a single ONT
- Broadcast packet rate limiting
- Anti-DoS attack
- MAC filtering

4.12.1 Data Security of the GPON Interface

Because the GPON system works in broadcast mode in the downstream direction, malicious users can easily attack other users' messages. To enhance data security of the user, the GPON downstream provides AES-128 encryption.

4.12.2 Traffic Suppression

- Broadcast storm suppression
 - When the broadcast traffic including the unknown unicast and multicast traffic exceeds the threshold that the user sets, the broadcast traffic will be discarded till the traffic is reduced to an allowable range, thereby avoiding network congestion and ensuring normal operation of the network services.

4.13 Alarm Features

- Dying gasp
- Receiving optical power too high
- Receiving optical power too low
- Transmission optical power too high
- Transmission optical power too low
- Port loopback alarm
- Loss of signal
- Loss of frame
- Signal degradation alarm
- Loss of GEM channel delineation

4.14 Performance Statistic Features

4.14.1 Ethernet Port Performance Parameters

- Frames transmitted
- Bytes transmitted

- Unicast frames
- Multicast frames
- Broadcast frames
- Frames received
- Bytes received
- Unicast frames received
- Multicast frames received
- Broadcast frames received

5 Technical Indices and Parameters

5.1 Physical Structure, Environmental and Electrical Indices

Table 5-1 Specifications and Environmental Indices of the ZXHN F6600R

Parameter	Nominal Value
Net dimensions	210mm (W) x 130mm (D) x 35mm (H) (Not including antenna)
Noise	Null
Heat dissipation mode	Natural heat dissipation
Power supply	Rated 12 V DC (through the external AC/DC adapter)
Mounting	Desktop- or wall-mount
Operating environment	0°C - 40°C
Relative humidity	5% - 95%
Atmospheric pressure	70 - 106 kPa
Parameter	Nominal Value

5.2 GPON Interface Indices and Parameters

Table 5-2 GPON Interface Indices of the ZXHN F6600R

Parameter	Nominal Value
Connector type	SC/APC
Number of PON	1
Fiber type	Single-mode fiber
Wavelength	Transmitting : 1310 nm (PON) Receiving : 1490 nm (PON) RF:1550 nm (CATV)

Parameter	Nominal Value
Compliant standard of the PON interface	ITU-T 984.x
Receiving rate of the optical interface	2.488 Gbps
Transmitting rate of the optical interface	1.244 Gbps
Transmission wavelength range	1290 - 1330 nm
Root-mean-square spectral width of the transmitting end	< 1 nm (spectral width: 20 dB)
Output optical power	0.5 - 5 dBm
Optical power of the transmitter in output OFF status	< -45 dBm
Extinction ratio	> 10 dB
Receive range	1480 - 1500 nm
Receive sensitivity	-27 dBm
Saturation optical power of the receiver	-8 dBm
Optical link length	20 km

5.3 Key Technical Indices

Table 5-3 Key Technical Indices of the ZXHN F6600R

Parameter	Nominal Value
Configurable VLAN ID range	1 - 4094
Capacity of the MAC address table	1K
Capacity of the multicast table	1K
IGMP join delay	< 10 ms (single channel)
IGMP leave delay	< 10 ms (single channel)
Startup time	80s (default)
T-CONTs	8
GEM ports	256

6 Standards Compliance

Table 6-1 Standards Compliance

Standard	Description
ITU-T G.984.1	General characteristics for Gigabit-capable Passive Optical Networks (GPON)
ITU-T G.984.2	Gigabit-capable passive optical networks (GPON): Physical media dependent (PMD) layer specification
ITU-T G.984.3	Gigabit-capable Passive Optical Networks (G-PON): Transmission convergence layer specification
ITU-T G.984.4	Gigabit-capable Passive Optical Networks (G-PON): ONT management and control interface specification
ITU-T G.984.5	Gigabit-capable Passive Optical Networks (G-PON): Enhancement band
Broadband Forum TR-101	Migration to Ethernet-Based DSL Aggregation, April 2006
Broadband Forum TR-156	Using GPON Access in the context of TR-101, December 2008
IEEE Std 802.1D-2004	Media Access Control (MAC) Bridges
IEEE Std 802.1Q-2005	Virtual Bridged Local Area Networks
IEEE Std 802.1ad-2005	IEEE Standards for Local and Metropolitan Area Networks—Virtual Bridged Local Area Networks—Revision—Amendment 4: Provider Bridges
IEEE 802.3-2005	IEEE Standard for Information technology—Telecommunications and information exchange between systems—Local and metropolitan area networks—Specific requirements Part 3: Carrier sense multiple access with collision detection (CSMA/CD) access method and physical layer specifications (Includes: IEEE Std 802.3ae-2002, IEEE Std 802.3af-2003, IEEE Std 802.3ah-2004, IEEE Std 802.3aj-2003, IEEE Std 802.3ak-2004)(Revision of IEEE 802.3-2002)

Standard	Description
IEEE 802.1X-2004	IEEE Standards for Local and Metropolitan Area Networks: Port-Based Network Access Control
ITU-T Y.1291	An architectural framework for support of Quality of Service in packet networks
ITU-T H.248.1 V2	Gateway control protocol: Version 2
ITU-T H.248.1 v3	Gateway control protocol: Version 3
YD/T 1292-2003	Technical specification for media gateway control protocol based on H.248
IETF RFC3261	SIP: Session Initiation Protocol
IETF RFC1112	Host extensions for IP multicasting
IETF RFC2236	Internet Group Management Protocol, Version 2
IETF RFC 3376	Internet Group Management Protocol, Version 3
ITU_T K.21	Resistibility of Telecommunication Equipment Installed in Customer Premises to Overvoltages and Overcurrents
EN60950	Information technology equipment. Safety, General requirements

7 Glossary

Table 7-1 Glossary

Acronym	Full Term
OMCI	ONU Management and Control Interface
AES	Advanced Encryption Standard
HSI	High Speed Internet
FXS	Foreign Exchange Station
ARP	Address Resolution Protocol
MIMO	Multiple-Input Multiple-Output
FAT	File Allocation Table
NTFS	New Technology File System
PPP	Point to Point Protocol
IPCP	IP Control Protocol
PPPoE	Point to Point Protocol over Ethernet
DHCP	Dynamic Host Configuration Protocol
CDR	Call Detail Record
CoS	Class of Service
GEM	G-PON Encapsulation Mode
DBA	Dynamic Bandwidth Allocation
EMS	Element Management System
ACS	Auto-Configuration Server
LED	Light Emitting Diode
FEC	Forward Error Correction
FTP	File Transfer Protocol
TFTP	Trivial File Transfer Protocol
WMM	Wi-Fi Multi-Media
IGMP	Internet Group Management Protocol
MLD	Multicast Listener Discover
DNS	Domain Name System

Acronym	Full Term
FTTH	Fiber to the Home
GE	Gigabits Ethernet
GFP	Generic Framing Procedure
GPON	Gigabit-capable Passive Optical Networks
IMS	IP Multimedia Subsystem
IP	Internet Protocol
IPTV	Internet Protocol Television
ITU	International Telecommunication Union
LTE	Long Term Evolution
L3	Layer 3
WAN	Wide Area Network
LAN	Local Area Network
MAC	Media Access Control
SNTP	Simple Network Time Protocol
NAT	Network Address Translation
L2TP	Layer Two Tunneling Protocol
PPTP	Point to Point Tunneling Protocol
RTSP	Real Time Streaming Protocol
ALG	Application Layer Gateway
SLAAC	
OLT	Optical Line Termination
ONT	Optical Network Terminal
ONU	Optical Network Unit
PON	Passive Optical Network
POTS	Plain Old Telephone Service
SN	Serial Number
QoS	Quality of Service
RARP	Reverse Address Resolution Protocol
SP	Service Priority
SP	Strict Priority
STB	Set Top Box

Acronym	Full Term
UNI	User Network Interface
VLAN	Virtual Local Area Network
VoD	Video on Demand
VoIP	Voice over Internet Protocol
WPS	Wi-Fi Protected Setup
WRR	Weight Round Robin