

4 PON PORTS GPON OLT

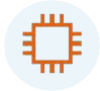

Dedicated Chip



USB Interface



Software Customization



Layer3 Switching

SUPREME



Brief Views

GPON OLT **SUPOLT-4G1** completely meet relative standard of ITU G.984.x and FSAN, which is 1U rack-mounted device with 1 USB interface, 4 uplink GE ports, 4 uplink SFP ports, 2*10GE uplink ports and 4 GPON ports. Each GPON port supports the splitting ratio of 1:128, The GPON system supports up to 512 terminal connections.

This product meets the requirements in device performance and size of compact server room as the product has high performance and compact size, which convenient and flexible to use, and is easy to deploy as well. Moreover, the product meets the requirements of promoting network performance, improving reliability and reducing power consumption in the perspective of access network and enterprise network and is applicable to three-in-one broadcast television network, FTTP (Fiber to the premise), video monitoring network, enterprise LAN (Local Area Network), internet of things and other network applications with a very high price/performance ratio.

Functional Feature

- Meet ITU-T G.984/G.988 standard and standards of Chinese Communication Industry
- Support OMCI Protocol
- 1U height 8PON OLT product in compact design of Pizza-Box
- Fan speed adjust automatically
- 1+1 Pluggable power module
- Complete PON protection switching function
- Layer 2 Switching Function
 - OLT equips with very powerful layer 2 Full Wire Speed Switching and completely supports layer 2 protocol. OLT supports varieties of layer 2 functions like TRUNK, VLAN, LACP, rate limit, port isolate, queue technology, flow control technology, ACL and so on, which provides technical guarantee for the development of multi-service integrated.
- QOS Guarantee
- GPON Products maintains fully-improved DBA with excellent QoS service capabilities. DBA meets different QoS requirements from different service flow in latency, jitter, packet loss rate.
- Easy-to-Use Management System
 - Support management method of CLI, WEB, SNMP, TELNET, SSH and meet OMCI standard, through OMCI channel protocol service management can be realized, including ONT function parameter set, T-CONT business lines and amount, Qos parameters, configuration information request, performance statistics, auto-reporting of running events in system, configuration for ONT from OLT, fault diagnosis and management of performance and safety.

Product Interface

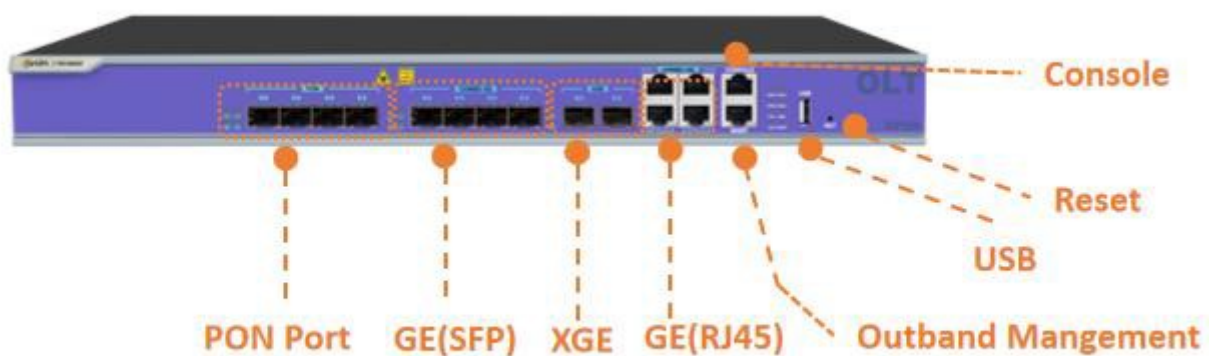

Product Specification

Rack	Type	1U 19-inch standard box		
Uplink Port	COMBO port	4 10/100/1000M auto-negotiation Ethernet ports 4 SFP interfaces		
	10-Gigabit	2 SFP+ interfaces		
PON Port	Quantity	4		
	Physical interface	SFP		
	Interface type	GPON: ITU-TG.984.2 Class B+/Class C+		
	Max splitting ratio	GPON: 1:128		
Management Port		1 100/1000BASE-Tx out-band Ethernet port 1 CONSOLE local management port		
USB Port		1 USB interface (It's used to backup configuration, upgrade program and record log information)		
PON Port attribute	Transmission distance	20KM		
	Port rate	GPON: Downstream: 2.5Gbps Upstream: 1.25Gbps		
	Wavelength	Forwarding: 1490nm Receiving: 1310nm		
	Interface type	SC/UPC		
	Fiber type	9/125μm SMF ((Single Mode Fiber)		
	Light transmission power	Class B+: +1.5~+5dBm	Class C+: +3~+7dBm	
	Receiving sensitivity	Class B+: -28dBm	Class C+: -30dBm	
	Saturation power	Class B+: -8dBm	Class C+: -12dBm	
Network management method		Support CLI、SNMP、TELNET、SSH、WEB		
Business capabilities		<ul style="list-style-type: none"> ➤ Support device log, device upgrade, device management, condition monitoring, configuration management, and user management ➤ Layer 2 switching configuration management: Like port management, VLAN, RSTP, IGMP, ACL, QOS and so on. ➤ PON function configuration management: Like OLT authentication, DBA template, service template, line template and so on. ➤ Layer 3 function: support static routing, dhcp-relay and vlanif configuration. 		
Backplane Bandwidth		63G		
Size		440*44*276mm		
Weight		4.0Kg		
Power supply	220VAC	AC: 100V~240V, 47~63Hz		

	-48DC	DC:-40V~-72V
	BBU (Backup Battery Unit)	DC: 11V~14V Function: When the regular power supply is cut off, it can be switched to the backup power supply, and when the regular power supply resumes, it will switch back to the regular power supply and charge the backup power supply.
Maximum power		45W
Working environment	Working temperature	-15~50°C
	Storage temperature	-40~85°C
	Humidity	5~90% (Non-condensing)

Typical Application

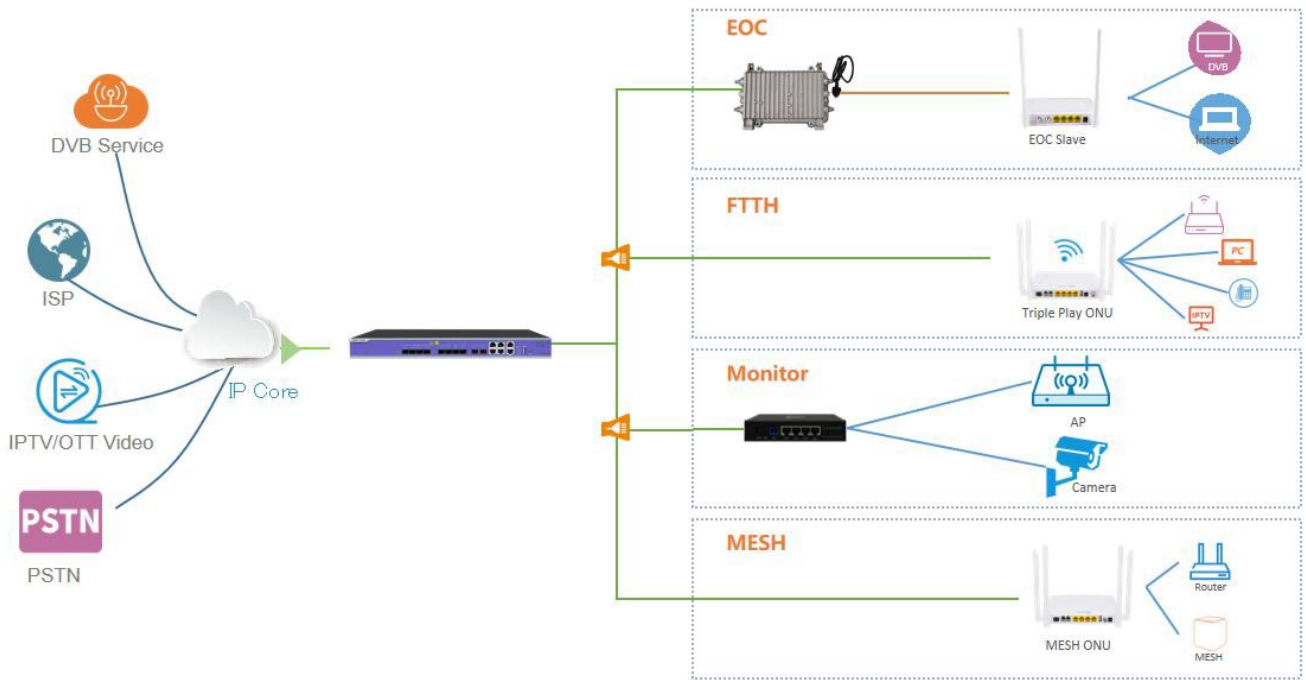

SUPREME

